

THE

General Radio EXPERIMENTER

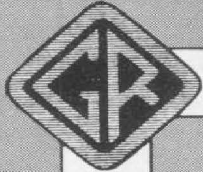

VOLUME XXIV No. 5

OCTOBER, 1949

Copyright, 1949, General Radio Company, Cambridge, Mass., U. S. A.

ELECTRICAL MEASUREMENTS AND THEIR INDUSTRIAL APPLICATIONS

A SMALLER VARIAC SPEED CONTROL

Also
IN THIS ISSUE

Page

RETURNING INSTRUMENTS FOR REPAIR 6

Introduction

In the April issue of the *Experimenter*, the TYPE 1700 Variac Speed Controls* were described for operation of shunt motors having ratings up to 1/3 h.p. The TYPE 1701 Controls are now offered for applications requiring up to about 1/5 h.p. output. A very compact design has been achieved

by employing miniature selenium rectifiers instead of the full-wave gas rectifier used in the TYPE 1700 Control. The selenium rectifiers also

*W. N. Tuttle, "Variac Motor Speed Controls," *General Radio Experimenter*, April, 1949.

Figure 1. Panel view of the Type 1701-AK Variac Speed Control.

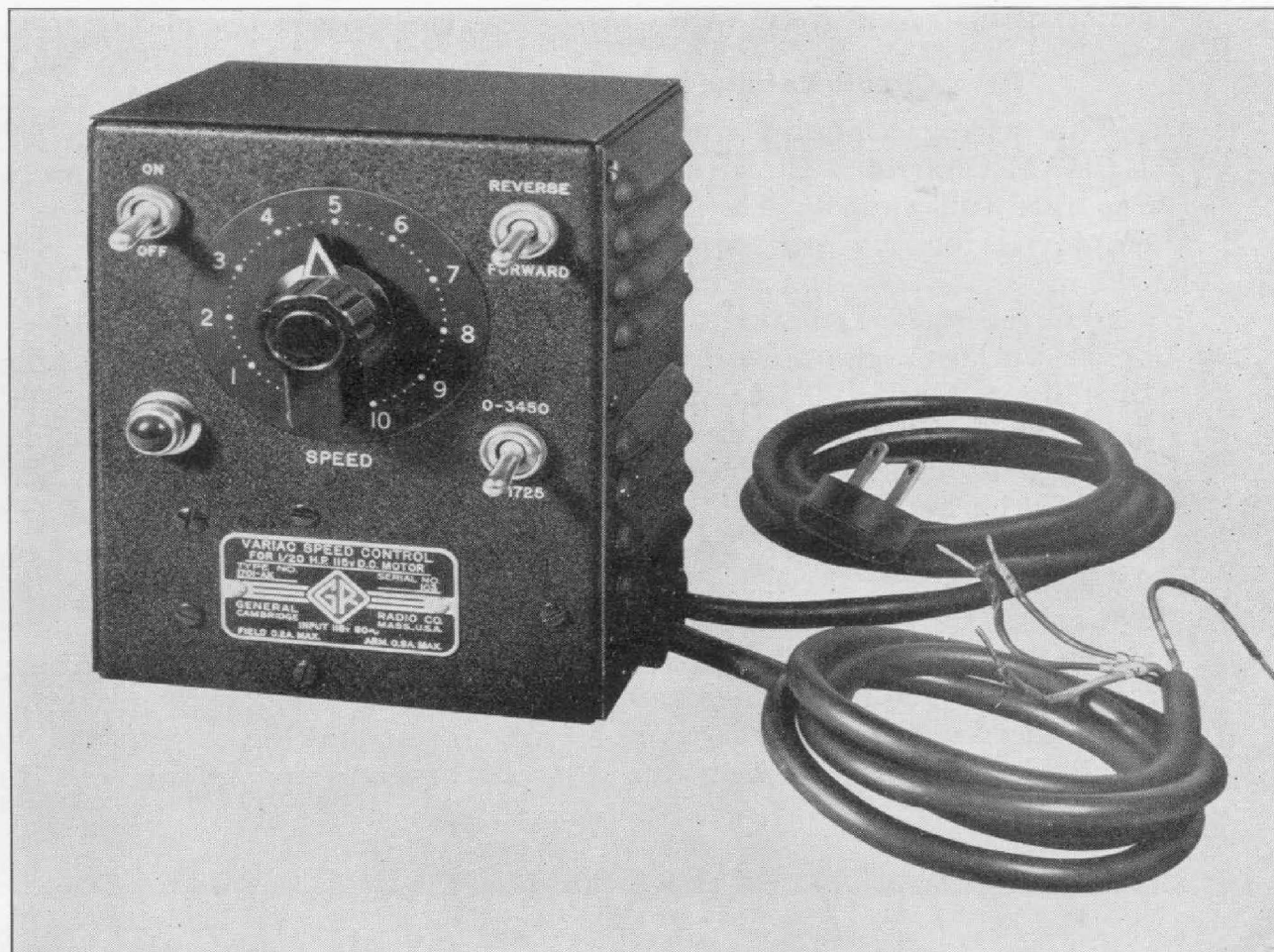

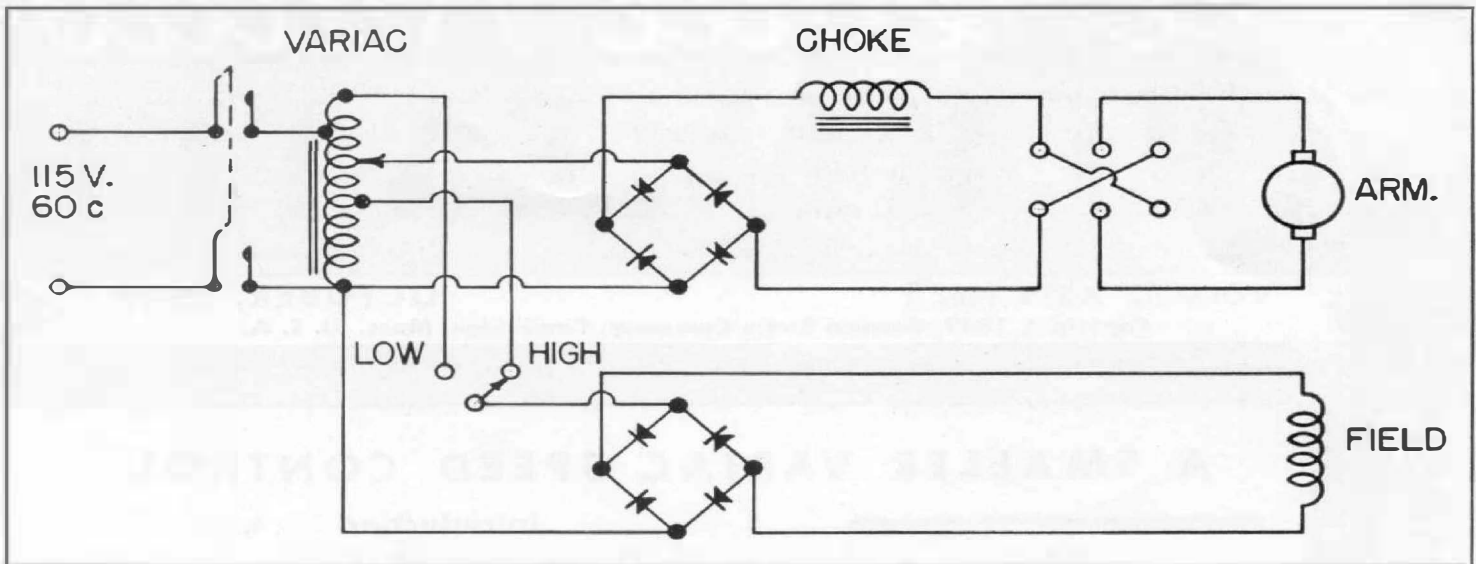

Figure 2. Circuit of Type 1701-AK Speed Control. Circuit of Type 1701-AU is similar but furnishes the field supply at a lower voltage and has only a single speed range.

permit considerable circuit simplification and reduction in cost and eliminate the need for a time delay when the unit is first turned on. Two types are offered. The TYPE 1701-AK is for shunt motors of standard design. The TYPE 1701-AU is for series or universal motors converted by reconnection for operation at constant field excitation.

Circuit Details

The wiring diagram for the TYPE 1701-AK Control is shown in Figure 2. Separate full-wave bridge rectifiers are employed for the armature and field. The adjustable output voltage of the Variac feeds the armature through one of the bridges and a choke, which, as in the larger TYPE 1700 Controls, serves both to reduce the ripple and to improve the regulation. Fixed taps on the Variac furnish the field excitation through the second rectifier bridge. Normally the field is left fully excited, and the speed is controlled by adjustment of the armature voltage from zero to maximum. For applications requiring increased maximum speed at reduced torque, however, the field excitation can be reduced by a

two-position speed-range switch. The line power switch serves as the motor start and stop switch, because the selenium rectifiers are ready for instant operation without warm up.

Construction

The general appearance of the control is shown in the photograph, Figure 1.

The cabinet is $6\frac{3}{8}$ inches high, $5\frac{1}{4}$ inches wide, and $3\frac{5}{8}$ inches deep. The louvers make the width $\frac{1}{2}$ inch greater overall, and the knobs and switches add about $\frac{3}{8}$ inch to the depth. Ventilation is entirely through the side louvers, so the cabinet can rest on its base and the control can be operated conveniently on a laboratory bench without being permanently installed. Further to facilitate laboratory use, and to simplify installation, the power cord and a four-conductor motor cord are permanently attached to the control.

Figure 3 shows the internal construction and the method of attachment of the cover. The base is integral with the panel. The cords are attached to the base, and the cover is notched so that it can be removed without disturbing the



wiring. This construction permits two alternative methods of mounting in permanent installations. Either the control can be mounted through its base and the cover left free, or the cover can be permanently mounted on a vertical surface through holes in its back and the control in turn attached to the cover. The latter arrangement makes it possible to remove a unit with its connecting cords for servicing by taking out only the small screws attaching it to the cover.

Performance

The internal resistance of the armature supply circuit is very low, about 12 ohms compared with the armature resistance of about 42 ohms. Hence, at base speed, the regulation is only slightly greater than when the motor is operated directly from a d-c line. Families of speed-torque curves for the high and

low speed ranges of the control are shown in Figure 4. As with motors operated from the larger TYPE 1700 Variac Speed Controls, the rise in speed between full load and no load is the same at all speed settings, so the regulation expressed as a percentage of the full-load speed is inversely proportional to the speed setting. The r.p.m. rise is about 470 and 680 r.p.m. for the low and high speed ranges, or about 27 per cent and 20 per cent, respectively, at the maximum speed setting for each range. This compares favorably with the performance of the larger TYPE 1700 Controls, the difference being largely in the inherently poorer regulation of the smaller motor.

The Type 1701-AU Control for Converted Universal Motors

This model of the control makes it possible to obtain adjustable constant-speed operation from a motor of the

Figure 3. Interior view of control.

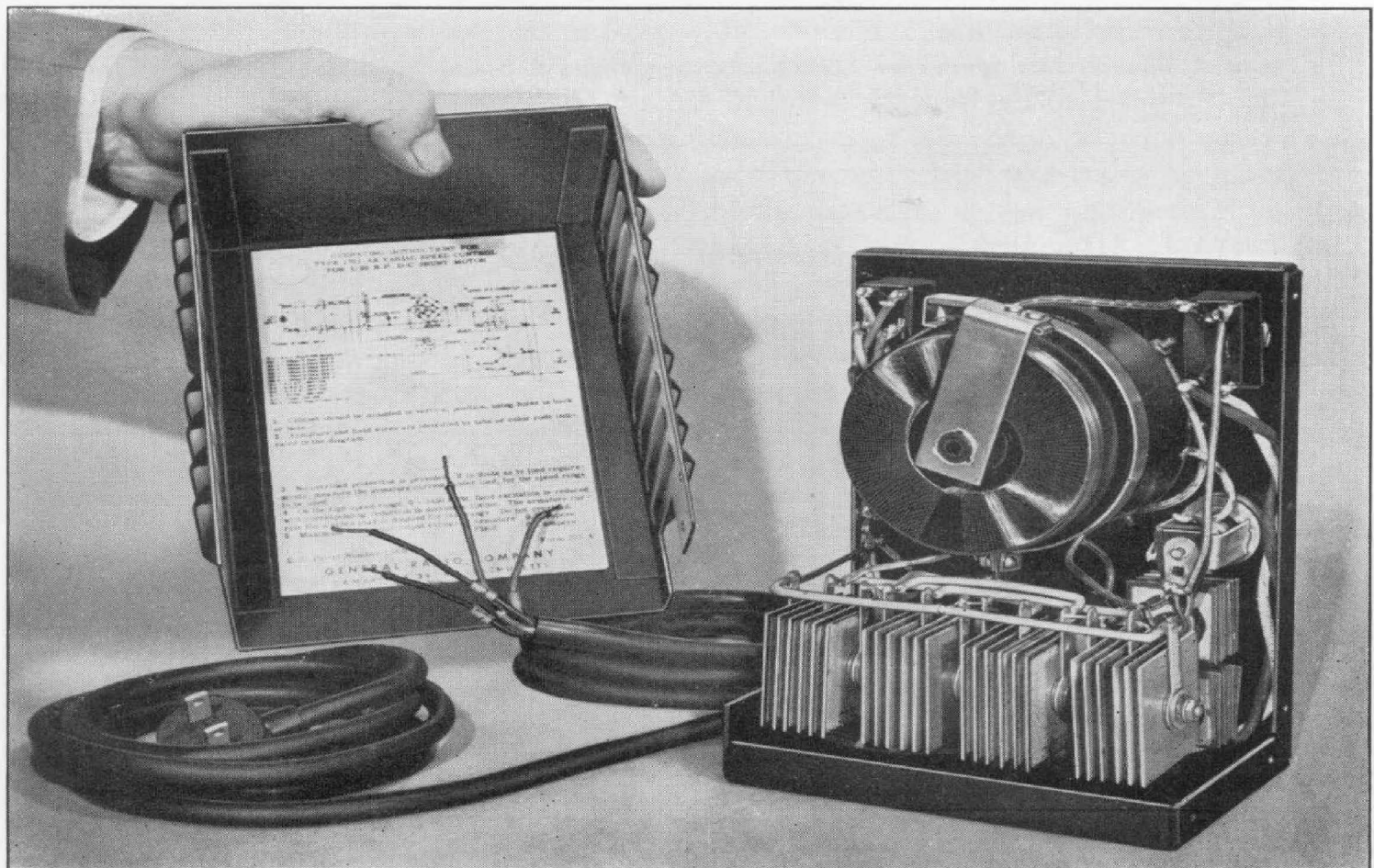

series or universal type by separately exciting the field at the voltage normally appearing across it at full load in the series connection and applying an adjustable voltage to the armature alone. The performance is exactly the same as for a shunt motor, but the field excitation is supplied at lower voltage and higher current.

The reasons for supplying this model of the control are that universal motors are widely available in a large number of types, are relatively inexpensive, and run at high efficiency. They are the only motors generally available for operation at speeds up to 10,000 r.p.m. and higher, and they are very compact for a given power output. Another consideration is that with this control various types of equipment run by universal motors can be modified for operation at adjustable constant speed without changing the motor. Finally, because of the high speeds available, operation on a constant torque basis is possible over an extreme-

ly wide range of speeds, up to 50:1 or even 100:1. The only disadvantages of any consequence in the universal motor appear to be that the high operating speed causes greater brush and bearing wear, and that for some applications a relatively high gear or pulley reduction ratio must be employed.

It is clear that with d-c operation under steady load conditions the motor will perform identically whether the field and armature are connected in series or separately excited at the same voltages. One motor tested, for example, had a rating of $\frac{1}{15}$ h.p. at 5000 r.p.m., 1.25 amperes, and 115 volts. The field resistance was 12.5 ohms, so the field voltage at full load was 15.6 volts and the armature voltage 99.4 volts in the usual series connection. When these voltages were supplied separately to the armature and field, operation at rated load was unaffected, but the speed, instead of varying widely with the load, was maintained within close limits. The

Figure 4. Speed-torque curves for 1/20 h.p. shunt motor with Type 1701-AK Control for the high and low speed ranges.

Figure 5. Speed-torque curves for 1/15 h.p. converted universal motor used with Type 1701-AU Control compared with a-c operation of the motor.

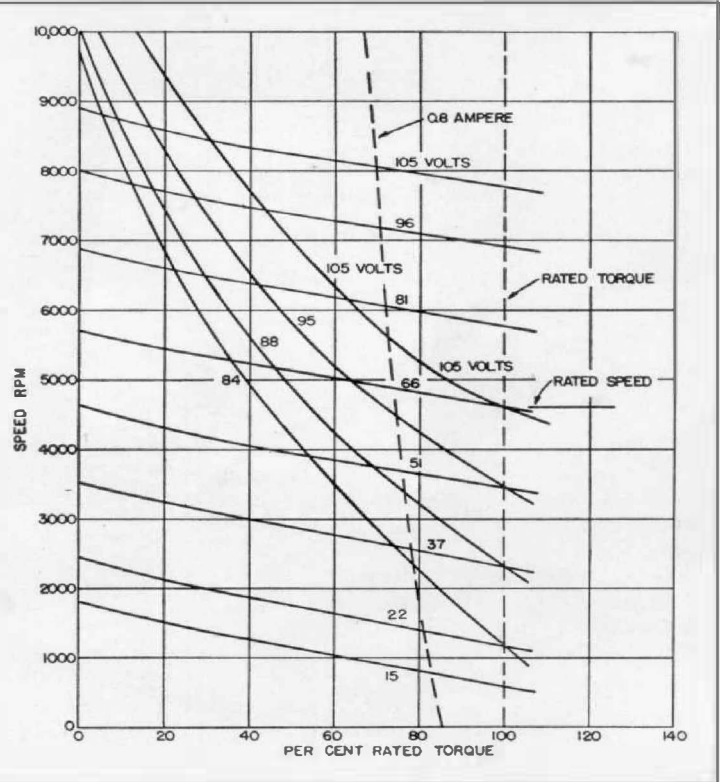
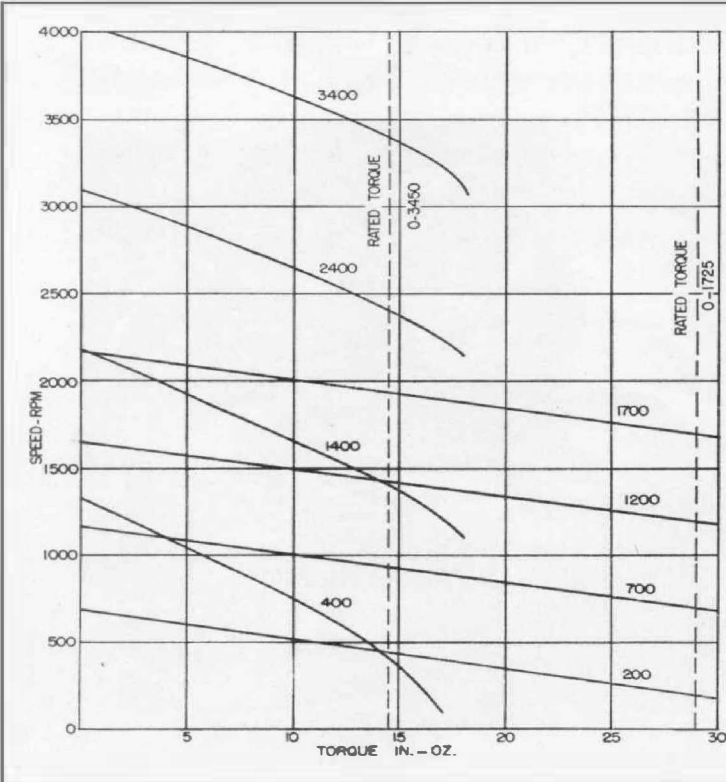



very high starting torque of the series connection must be given up, on the other hand, for the relatively lower starting capabilities of the shunt motor. When, as in the TYPE 1701 Control, the armature voltage is adjusted to set the speed, however, heavy loads can be started without difficulty by turning up the speed control.

An important feature of the TYPE 1701-AU Control is that it takes advantage of the greatly improved performance of a universal motor on dc in comparison with the usual operation on ac. Greater power output can be obtained with a motor of given size, the efficiency is higher, and commutation is very much better. With a-c operation, the brushes must be set off neutral for the best commutation, so that motors for reversing service are not entirely satisfactory. When motors are operated on dc, as with the TYPE 1701 Control, excellent reversing characteristics are obtained.

Figure 5 illustrates the comparative performance of a $\frac{1}{5}$ h.p. universal motor working on adjustable a-c voltage from a Variac, and working on dc with fixed field excitation and adjustable armature voltage obtained from the TYPE 1701 Control. This motor is suitable for use with the control, although its rated current for a-c operation, 1.25 amperes, is considerably greater than the maximum continuous current, 0.8 ampere, which can be provided by the control. This is because on dc, even with 105

volts applied and with a load of rated torque, the armature current is only about 1 ampere and the speed is about 70 per cent greater than the rated speed for a-c operation. The 0.8 ampere current limit of the control is shown by a dashed line. It is seen that this current will provide 80 per cent of rated torque at 8000 r.p.m. instead of the rated 4600 r.p.m. The combination of the control with this motor, then, will provide continuously about 40 per cent more than the motor rated power, or about $\frac{1}{11}$ h.p. instead of $\frac{1}{5}$ h.p. Because of these characteristics, considerably increased output can be obtained from a given universal motor when used with the TYPE 1701-AU Control wherever operation at increased speed and somewhat reduced torque can be provided for. Even without exceeding the rated speed, about 75 per cent of rated torque, or $\frac{1}{20}$ h.p., can be obtained from this combination without exceeding the continuous duty rating of the control.

The dashed characteristics show the comparative performance of the motor run in the series connection from adjustable a-c voltage. The usual inverse speed-torque characteristic contrasts greatly with the constant-speed characteristics obtained on dc with separate field excitation. Corresponding operating voltages are also marked on the curves. The great improvement in both regulation and efficiency is apparent.

— W. N. TUTTLE

SPECIFICATIONS

	<i>Type 1701-AK</i>		<i>Type 1701-AU</i>	
Supply Frequency	60 c	50 c	60 c	50 c
Supply Voltage	105-125 v	105-120 v	105-125 v	105-120 v
D-C Output Armature Voltage	0-115 v		0-115 v	
D-C Output Armature Current	0.8 a. max.		0.8 a. max.	
D-C Output Field Voltage	38 v, 115 v		16 v	
D-C Output Field Current	0.2 a.		1.0 a.	



Speed Range: Motor rated speed down to zero at constant torque. A working range of 30:1 can be satisfactorily employed with the TYPE 1701-AK Control and up to 50:1 or more when the TYPE 1701-AU Control is used with a converted universal motor having a speed rating of 5000 r.p.m. or higher. Two speed ranges, one up to rated speed and one at reduced field excitation up to approximately twice rated speed, are provided in the TYPE 1701-AK Control. Only a single range is provided in the TYPE 1701-AU Control because of the higher rated speeds of universal motors.

Motor: The TYPE 1701-AK Control can be used with any 1/20 h.p. 115-volt d-c shunt motor or with a 1/15 h.p. motor when the current consumption is within the rating of the control. Speed ranges marked on the panel are for motors having a base speed of 1725 r.p.m. and reduced field operation up to 3450 r.p.m. as provided by Bodine Motor Model NSH-33 listed below.

The TYPE 1701-AU Control can be used with 1/20, 1/18, or 1/15 h.p. universal motors when the current consumption is within the rating of the control. When operating at rated current, such motors will furnish rated torque at up to 150 per cent or more of rated speed, giving output power substantially greater than the rating. Motors of the four-wire reversible type can be

used without modification. Uni-directional motors must be provided with separate field leads. Bodine type NSE-12 motors 1/8 h.p., 5000 r.p.m., for reversing service are stocked as listed below. Motors of other ratings or with built-in gear reduction can be obtained from the manufacturer.

Overload Protection: No protection for starting load or momentary overload is required. A slow-blow fuse is provided in the TYPE 1701-AU Control only as a protection against damage from stalling when starting an excessively heavy load.

Reversal: Motors with brushes set on neutral give excellent reversing performance with either control. Sparking at the commutator may occur if it is attempted to reverse motors having brushes set for a single direction of rotation.

Mounting and Wiring: The control can be mounted either through the bottom or the back and can be used unmounted on a laboratory bench. Mounting must permit ventilation through the side louvers. A 5 1/2 foot power cord and a 3 1/2 foot four-conductor motor cord are permanently attached to the control.

Dimensions: Height 6 13/16 inches, width 5 1/16 inches, depth 4 5/8 inches overall.

Weight: Six pounds for either model.

Type		Code Word	Price
1701-AK	Variac † Speed Control, 115 v, 50-60 c.p.s., for D-C Shunt Motor	WINDY	\$65.00
1701-AU	Variac † Speed Control, 115 v, 50-60 c.p.s., for Converted Universal Motor	WEARY	65.00
MOD-1	Bodine Model NSH-33 Sleeve-Bearing D-C Shunt Motor, 1/20 h.p., 1750 r.p.m., for use with TYPE 1701-AK Control	MOTOR*	24.50
MOD-4	Bodine Model NSE-12 Sleeve-Bearing Reversible Universal Motor, 1/18 h.p., 5000 r.p.m., for use with TYPE 1701-AU Control	MOTOR*	14.26

*To order speed control with motor, use compound code word, WINDYMOTOR or WEARYMOTOR.

†Trademark registered in U.S.A. U.S. Patent No. 2,009,013.

RETURNING INSTRUMENTS FOR REPAIR

When General Radio instruments are returned to the Service Department for repair or reconditioning, the time consumed in handling the job can be held to a minimum if the procedure outlined here is followed.

Before returning an instrument for any reason, write to the Service Department, stating the reason for return, and

giving the type and serial numbers. Shipping instructions, where necessary, and a Returned Material Tag, will then be furnished by the Service Department. Do not ship equipment to our plant without first obtaining instructions. Unauthorized shipments are made at the owner's risk. We cannot accept responsibility for them.



When the return is to be made for repair, please give us complete information on the observed defects: their nature, symptoms, etc., as well as a sketch of the external circuits to which it is connected. When we have all this information, we can often diagnose the trouble and correct it by furnishing a replacement part.

Often instruments have been returned with no greater trouble than a blown fuse or deteriorated vacuum tube. Occasionally equipment has been returned in first-class condition because the operating instructions supplied with it had not been followed, or possibly were not fully understood. Frequently what appears to be unsatisfactory performance can be traced to the external circuit with which the instrument is being used.

Even when equipment must be returned for repairs, a detailed statement of the trouble may be very helpful. Analysis of this information sometimes shows that the trouble is caused by a single defective component which can be easily replaced. Our laboratory will know what condition needs correction, and no time will be lost in making extra preliminary checks.

The letter or purchase order authorizing necessary work to an instrument should always be mailed so as to arrive before the shipment. The *Returned Material Tag* should always be fastened to the instrument when shipment is made. If this is not done, serious delays will result, as in some cases we would have no way of knowing by whom the instrument was shipped.

In accordance with the procedure of their purchasing divisions, some of our customers request a quotation to cover the cost of reconditioning equipment. It

is our practice to submit an estimate based on records of previous charges for equipment of the same type and age. This estimate is not a definite quotation, but is the form of minimum and maximum prices.

We have found it necessary to follow this plan rather than to test a returned instrument completely and then to quote an exact charge, which would inevitably be in excess of what the customer expected because of the laboratory time required for testing. Since repair charges depend upon the cost of the labor and material involved, a considerable saving can thus be made in the repair charge.

If, upon inspection of a returned instrument, it is found that the cost of reconditioning will be in excess of normal charges, the customer is advised of the maximum cost, and no work is done until a reply is received.

In reconditioning a returned instrument we clean it thoroughly; check and resolder any connections that may have weakened; replace or repair any component parts that have become worn, deteriorated, or damaged; tighten all assembly and mounting screws; clean the panel and polish the cabinet.

It is then sent to the laboratory for final test and recalibration. The repaired instrument must pass the same test as a new instrument. If an obsolete type, it is tested under the specifications that were used when it passed through the laboratory originally. Because of the careful and complete reconditioning in our shop and laboratory, we are able to guarantee the instrument for one year, tubes and batteries excepted. This guarantee is identical to that which applied when the instrument was originally sold.

— H. H. DAWES



MISCELLANY

Recent Visitors to General Radio—Mr. A. Bruaux, Ateliers de Constructions Electriques, Charleroi, Belgium; Mr. P. L. Jain, Jubbulpore, C.P., India; Mr. Arun Prasad, Bangalore, South India; Dr. R. A. Smith, Telecommunication Research Establishment, Great Malvern, England; Dr. H. Van Dijk, Kamerlingh-Onnes Laboratory, Leiden, Holland; and Mr. Gunnar Hammerik of Maskin-Aktieselskapet Zeta, Oslo, sales representatives for General Radio products in Norway.

Papers — by Ivan G. Easton, Engineer, "Amplifier and System Measurements," tenth lecture in the Spring Educational Series of the Audio Engineering Society, New York, May 19.

— by Arnold P. G. Peterson, Engineer, "The Measurement of Non-Linear Distortion," at the Pacific Coast Convention of the I.R.E., San Francisco,

and at a meeting of the Seattle Section of the I.R.E.

In Denmark, we have been represented for the past year by Mogens Bang and Company, Copenhagen/Skordsborg. Our friends in Denmark will be glad to learn that, effective October 1, Mogens Bang and Company will be our exclusive representatives in Denmark.

Credits — Design and development of the TYPE 1001-A Standard-Signal Generator, described in our September issue, was carried out under the supervision of Eduard Karplus. Development engineer was A. G. Bousquet, author of the descriptive article.

Erratum

It has been brought to our attention that the caption of Figure 3 on page 3 of the August, 1949, *Experimenter* is incorrect. The caption should be "Circuit of the TYPE 1931-P1 A-M Detector Unit."

THE General Radio EXPERIMENTER is mailed without charge each month to engineers, scientists, technicians, and others interested in communication-frequency measurement and control problems. When sending requests for subscriptions and address-change notices, please supply the following information: name, company address, type of business company is engaged in, and title or position of individual.

GENERAL RADIO COMPANY

275 MASSACHUSETTS AVENUE

CAMBRIDGE 39

MASSACHUSETTS

TELEPHONE: TRowbridge 6-4400

BRANCH ENGINEERING OFFICES

NEW YORK 6, NEW YORK
90 WEST STREET
TEL.—WOrth 2-5837

LOS ANGELES 38, CALIFORNIA
1000 NORTH SEWARD STREET
TEL.—HOLlywood 9-6201

CHICAGO 5, ILLINOIS
920 SOUTH MICHIGAN AVENUE
TEL.—WABash 2-3820